

DATA SHEET



S-CR-LR-K-350-C Stationary Dry Chemical System

Features

- Fast knockdown of fires
- Unique fluidization techniques
- Extensive full-scale testing
- Proven reputation
- Listed by Underwriters Laboratories (UL) and USCG approved

Application

The ANSUL® S-CR-LR-K-350-C Stationary Dry Chemical System is manufactured to provide manual fire fighting protection for hazardous areas such as offshore platforms, loading racks, petrochemical facilities, marine applications, fuel storage areas, and heavy manufacturing operations.

Description

The ANSUL S-CR-LR-K-350-C Stationary Dry Chemical System combines the flexibility of a hand portable fire extinguisher with the greater suppression capability necessary to combat large Class B (flammable liquids and gases) and Class C (electrical) fires. The ANSUL Stationary Dry Chemical system is designed for operation by only one trained person, and is ideally suited for protection of hazardous areas where large fires must be extinguished before they have the chance to spread or increase in size. The ANSUL Stationary Dry Chemical system offers the quick response, large extinguishing agent capacity, longer discharge time, and increased flow rates necessary to combat these large fires. In short, the ANSUL Stationary Dry Chemical System protects areas where hand portable and wheeled fire extinguishers cannot. Standard units are manufactured with a skid base.

General Specifications

DRY CHEMICAL CONTAINER

The dry chemical tank shall be of welded steel construction, with two elliptical dished heads (either of one piece or segmented construction) with a welded circumferential seam.

The dry chemical tank shall be designed and constructed according to the latest ASME unfired pressure vessel code for a working pressure of 250 psi (17.2 bar). It shall be stamped with the appropriate ASME code symbol. For added protection, the storage vessel shall include 0.12 in. (3 mm) corrosion allowance.

The dry chemical tank shall be fitted with a gas tube arrangement to adequately fluidize the dry chemical, pressurize the dry chemical tank, and maintain a nominally constant pressure in the tank during discharge. The gas tube shall be provided with a check valve to prevent any possibility of dry chemical backup.

The dry chemical tank shall be fitted with one 4 in. (10.2 cm) ID (inside diameter) fill opening in the top head, and shall be provided with a discharge outlet suitable for the dry chemical hand hose line.

FILL CAP

The dry chemical tank shall be provided with one fill cap. The cap shall consist of a cast, anodized aluminum body equipped with two handles extending from opposite sides of the cap to permit hand tightening so that it is free from leakage under normal operating pressure without the use of tools. The cap shall be equipped with a 5/32 in. (4 mm) thick rubber gasket inserted in a machined recess.

A safety vent hole shall be located in the fill cap so that the cap is capable of pressure venting while at least 3 1/2 threads are still engaged.

PRESSURE RELIEF VALVE

An approved ASME pressure relief valve shall be furnished to prevent the pressure in the tank from exceeding 10% of the maximum working pressure of the tank.

DRY CHEMICAL

The dry chemical for this system shall be formulated and produced by the system manufacturer and meet the requirements for the system manufacturer and Underwriters Laboratories. The dry chemical shall be furnished in plastic pails with water-tight replaceable covers.

NITROGEN CYLINDER

The nitrogen cylinder provided for the system shall meet D.O.T. Code 3AA2015 and T.C. Code 3AAM154.

NITROGEN CYLINDER VALVE

The nitrogen cylinder shall be provided with an Underwriters Laboratories Listed Quick Opening valve, having the following capabilities:

1. To be opened manually from a remote location by means of a pneumatic actuator.
2. To be opened manually at the valve by:
 - a. Quick-Opening lever action
 - b. Conventional hand wheel action
3. All three opening methods shall be independent and shall not interfere with each other.
4. The valve shall be provided with an integral safety relief set at 3000-3360 psi (206.8-231.7 bar) to relieve at 3360 psi (231.7 bar) maximum at 160 °F (71.1 °C).
5. The valve shall be manually closed by conventional hand-wheel action.
6. The valve shall be provided with an integral pressure gauge reading from 0 to 3000 psi (206.8 bar), marked to show the operable range of pressure.
7. The valve shall be constructed of highly corrosion resistant materials throughout.

All moving parts subject to wear shall be of hardened stainless steel and/or beryllium copper alloy.

General Specifications (Continued)

NITROGEN CYLINDER STORAGE

The nitrogen cylinder shall be mounted in a vertical position. The method of mounting shall be designed to permit easy access of operation and replacement of the cylinder.

NITROGEN PRESSURE REGULATOR

The nitrogen supply shall be directed through one regulator for the cylinder. The regulator shall be designed for an inlet pressure of 3000 psi (206.8 bar) and shall be set to deliver nitrogen at a reduced pressure of 195 to 215 psi (13.4-14.8 bar). The regulator shall have a spring loaded pressure relief valve. It shall be connected to the nitrogen cylinder by 3/8 in. (10 mm) inside diameter (ID) wire or polyester braid hose.

VALVING AND PIPING

The valving and piping shall be installed so that for normal operation, the nitrogen from the cylinder passes through the regulator and piping into the agent tank to adequately fluidize and pressurize the tank. The flow of agent from the tank to the distribution system shall be controlled by a normally-open-ball-type manual valve.

Valving and piping shall be furnished so that after the extinguisher is used, the hose line may be cleared of agent by venting the pressure from the top of the tank through the hose line.

Piping and valving shall also be arranged so that pressure direct from the nitrogen cylinder may be directed through the hose lines, if desired, for maintenance operations.

DISTRIBUTION OUTLET PIPING

The dry chemical distribution outlet to the hose lines shall be assembled with 300 pound fittings, non-ferrous valves, stainless steel internal parts acceptable, and nonferrous hose adaptors. The assembly shall be painted with one coat of primer and a minimum of one coat of red epoxy finish coating.

BURSTING DISC

An optional bursting disc assembly consisting of a bursting disc union designed to rigidly hold the disc in place, and the disc itself shall be located at the tank outlet in the discharge pipe to ensure proper fluidization of the dry chemical prior to discharge. The disc shall be constructed of nickel and shall be pre-scored to ensure a positive full burst at rated pressure.

The pre-discharge delay as the dry chemical tank pressurizes shall be sufficient to ensure that the dry chemical will be properly fluidized through the action of the nitrogen being fed through the gas tube. The bursting disc shall also function as a vapor barrier to help prevent the migration of moisture into the dry chemical storage tank from the distribution piping.

Bursting discs shall be replaced after each use.

DRY CHEMICAL HOSE

The hose shall be horizontally braided with the maximum inside diameter expansion of 0.010 in. (0.25 mm) under a pressure of 200 psi (13.8 bar). The twist shall not exceed 10 1/2 degrees in either direction under the applicable UL test. The outside cover stock shall be pin pricked to permit diffusion of gases with four rows of holes for the entire length equally spaced on the circumference and 1 in. (2.5 cm) apart parallel to the axis. Holes shall be 1/32 in. (0.8 mm) deeper than the cover. A minimum of 25 effective holes per foot (30.5 cm) is required. The dry chemical hose shall be connected between the distribution piping from the dry chemical tank and nozzle for control and direction of the dry chemical stream.

HAND HOSE LINE NOZZLE

The nozzle shall consist of a two-position ball valve and barrel. The nozzle barrel shall be the converging-diverging anodized aluminum type. The nozzle ball valve assembly shall be chrome-plated brass.

The dry chemical nozzle valve supplied for the hose line shall consist of a cast brass body and handle, with integral components of suitable nonferrous metal or stainless steel. A nozzle holder is available to prevent damage to the nozzle and hose during transport and is held in place by a sturdy rod welded onto the hose reel.

The operating handle shall move in two positions, opened and closed. The handle shall control the movement of a spherically shaped plug mounted to revolve about an axis perpendicular to the longitudinal axis of the nozzle so that the dry chemical stream may be selectively shut off or permitted to discharge in a straight line through the plug and nozzle. The bore of the plug and nozzle shall be of the same diameter.

The dry chemical stream shall be shaped by discharge through a nozzle chamber provided with the tip having a plurality of orifices arranged to produce individual streams of dry chemical for impingement against the inner wall of the chamber so that they are directed forward to merge and combine, outside the nozzle, to form a stream of dry chemical of high density and moderate range.

HOSE REEL

The metal reel and manual rewind shall be specifically designed for use with the dry chemical hose. The hose reel shall be capable of containing all the hose specified. The hose reel sits on a high metal stand for easy access and is painted red to match the system. A hose reel locking device shall be incorporated into the reel to prevent reel movement during skid transportation.

ACTUATION

A pneumatic actuation system utilizing a nitrogen filled cartridge shall be provided to open the nitrogen cylinder and operate a selector valve at the tank or remote location and energize the extinguishing system to the nozzle. The cartridge triggering device shall include a pull pin release and a strike button, providing a two-step release.

SELECTOR VALVE

A UL listed selector ball valve shall be incorporated into the skid outlet piping and shall be triggered pneumatically by the nitrogen cartridge.

SKID

The skid shall be steel, welded construction, sized and reinforced to provide the required strength of the intended application, protected from corrosion by special surface treatments sandblasting, primer, and epoxy coating.

LIFTING BAR

A rugged steel lifting bar shall be provided with the skid unit and be bolted to the structural base for easy removal at the site. The lifting bar shall be suitable for single-point lifting, eliminating the need for any lifting slings and spreader bars. Its lifting point shall be above the skid assembly in line with the unit's center of gravity.

PAINT FINISH

The final assembled unit is protected from corrosion by special surface treatments, including sandblasting, primer, and red epoxy coating.

RELIABILITY

The dry chemical suppression system shall be designed and manufactured by a company having at least 25 years experience in the design and manufacture of large capacity dry chemical hand hose line fire suppression equipment.

Stationary Skid Unit Capacities

Part No.	Model	Agent / Charge	Finish	Hose / Length	Nozzle	Nominal Flow*	Effective Discharge Time**	Charged Weight	Approximate Range
470619	S-CR-LR-K-350-C (without burst disc)	Purple K/ 350 lb (159 kg)	Epoxy	1 in. x 100 ft (30.5 m)	LR-44	8.0 lb/sec (3.6 kg)	45 sec	1250 lb (567 kg)	45 ft (13.7 m)
407524	S-CR-LR-K-350-C (with burst disc)	Purple K/ 350 lb (159 kg)	Epoxy	1 in. x 100 ft (30.5 m)	LR-44	8.0 lb/sec (3.6 kg)	45 sec	1250 lb (567 kg)	45 ft (13.7 m)

* Flow rate is an average with a 10% tolerance used by UL
 ** Effective time is a visual determination of gas point and is approximate

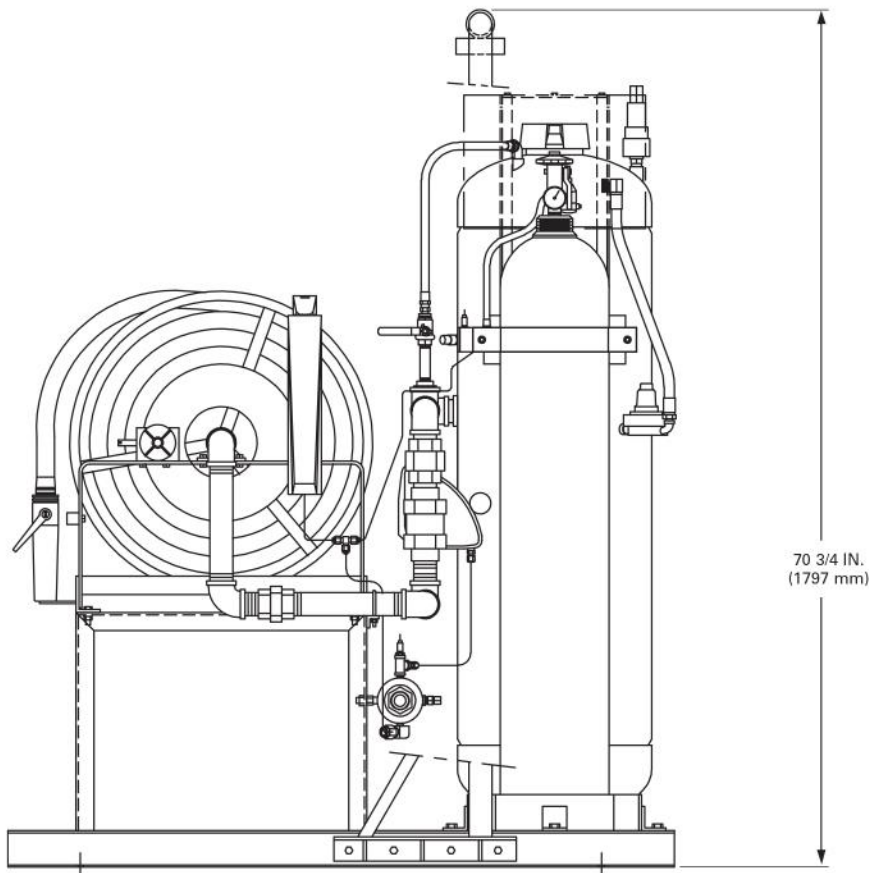
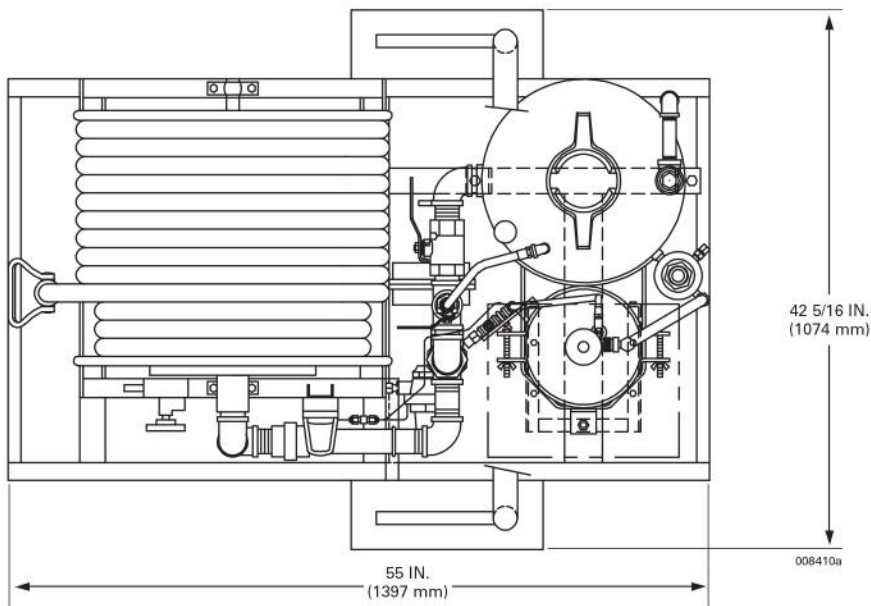

Safety Data Sheets (SDS) are available at www.ansul.com

Note: The converted metric values in this document are provided for dimensional reference only and do not reflect an actual measurement. ANSUL and the product names listed in this material are marks and/or registered marks. Unauthorized use is strictly prohibited.